

## A Basic Guide to Europe Dinghy Rigging

### The Basics:

- Use the smallest blocks available for the line size. Most of the blocks on your boat will be micro blocks.
- Examine all of your rigging and ensure that your lines do not cross or chafe against anything causing unnecessary friction. Friction can make your lines 50% more difficult – or even impossible – to pull on.
- Use the right line (diameter and type) for all of your control lines. Pre-stretch, Spectra line (with or without a cover) will take any loads the Europe can dish out – larger lines just add friction. See above.
- Cut off excess line lengths. You really won't need the extra line (honest, line only stretches over time) and the tails can get sucked into the adjacent blocks.
- Adding “purchase” reduces your work proportionally. See appendix for explanation.

— Good rigging looks (and is) clean and neat —

### Line Guide:

#### Small Sail Control Lines - 2-3 mm

- Boom Vang – 305 cm
- Cunningham – 75 cm
- Inhaul – 75 cm
- Outhaul - “Simple Outhaul” – 525 cm  
“Magic Outhaul” – 675 cm

Deck Control Lines – 4-5 mm; Four 305 cm lengths of different colors.

Main Sheet – 6-10 mm pre-stretch; 670 cm (or longer)

Traveler Line – 5-6 mm; approximately 152 cm

Halyard – Approximately 7,3 m of the smallest diameter line that doesn't jump the sheave. Or just change the sheave that it fits better in the top of the mast.

Bow Line – Essential item for Luther coaching. Not less than 14 m (class rules) of 6-8 mm non-absorbent line. Tie this snugly around your deck mast collar – not to (or through) that itty bitty eye strap on your bow.

## Outhaul:

- Your Outhaul must have a full range of motion – approximately 15-20 cm. You need to be able to pull the outhaul in all the way to the red band on your boom and let it off until the foot of your sail forms its maximum foot shelf depth. Some sails have a very short foot so that the outhaul cannot be pulled to the red band.
- Bungie rigged inside the boom will help to pull the outhaul line aft, making the line attached the sail slack and allowing the sail to ease off quicker.
- I advise rigging your outhaul on the outside of the boom first so it is easy to check and correct the full range of motion. Once you have it right, string it inside. I promise this will save hours of frustration!

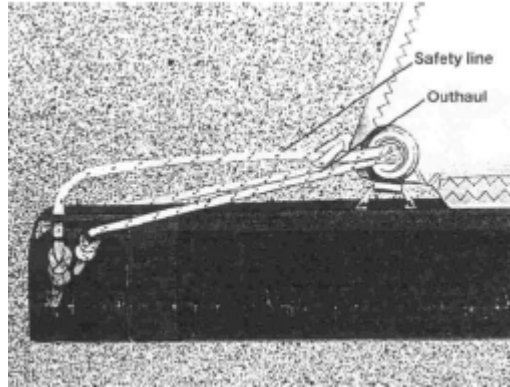

- Check that the entire system runs freely – especially at the gooseneck.
  - You may have to drill “dead-end” holes in your boom. Use the smallest hole the line will fit through.
- All booms should have a 15-20 cm safety line as shown above to keep you sailing when the outhaul breaks.
  - Mark your boom starting from the edge of the red band counting towards your mast. Outhaul position is key to your speed. Most of our fleet has been using approximately 1-2 cm increments, which seem to give a good measure and are large enough to see when hiking out.

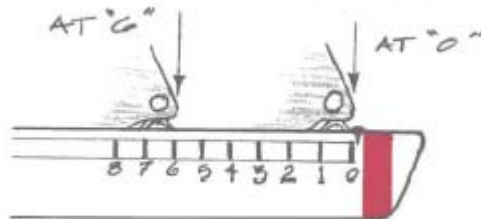

### • \*Boom line lengths\*

All line lengths given in the “Rigging Guide” include enough room for tight bowlines tied to the blocks, etc. (about 7,6 cm). The knots were untied before the lines were measured.

**Simple Outhaul** - 2:1 in diagram – converts to 4:1 when tied off to your deck control line block.

- Line 1: Dead end at front of boom, go through micro block and down through control line block: 322cm.
- Line 2: Tie onto sail clew then to inside micro block: 203 cm.

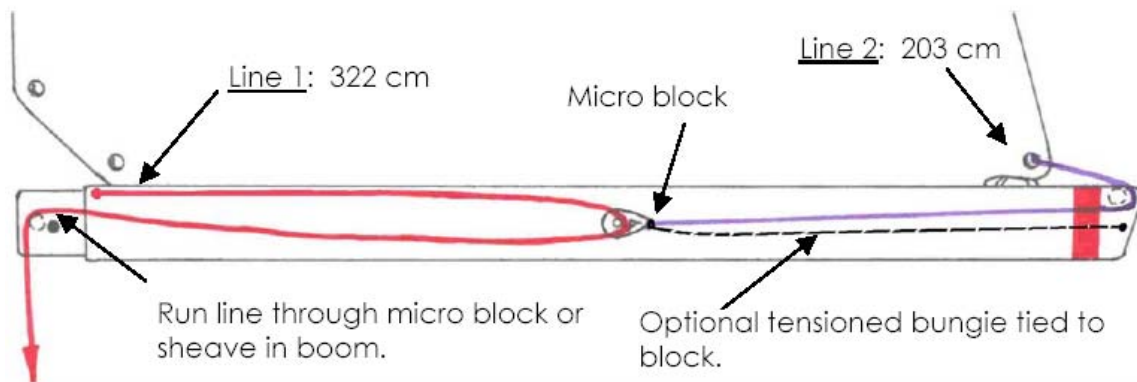

**The Magic Outhaul** - (an original by Luther Carpenter) 3:1 in diagram – converts to 6:1 when tied off to your deck control line block.

- Line 1: Dead end at front of boom then tie to 1st micro block located approximately in the center of the mainsheet and vang pad eyes: 102cm.
- Line 2: Tie to becket on 2nd micro block and go through 1st micro block, then back through the 2nd micro block and down through control line block: 430cm.
- Line 3: Tie onto sail clew and then to inside micro block: 145cm.

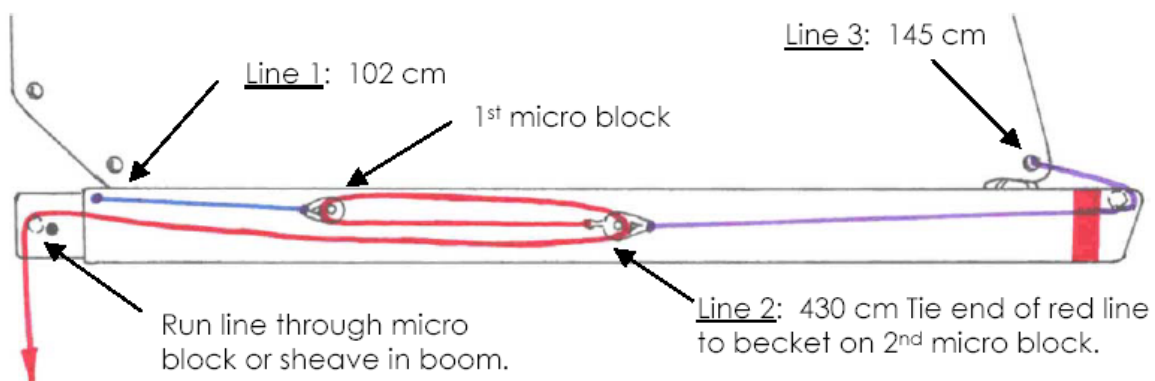

### **Add a Purchase to any Outhaul system**

- Note that adding this purchase will reduce your outhaul range.

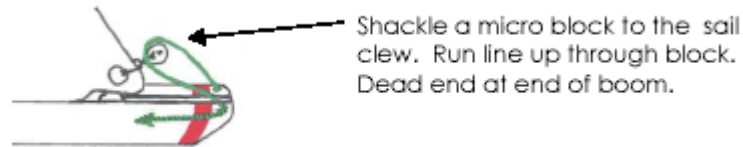

### **Inhaul:** (See “Lever Bar Vang” diagram)

- Make sure you can pull it all the way and ease it off.
- Luther recommends running the line out of the block, around the front of the mast and tied off on the other side to pull the sail forward rather than down.
- The Inhaul is led inside the Boom gooseneck and a Vang block up through a small block attached to the gooseneck plate, through the sail grommet and tied off to a bent shackle bolted to the gooseneck plate.

### **Cunningham:** (See “Lever Bar Vang” diagram)

- Make sure you can pull it all the way on (grommet to the boom if necessary!) and ease it completely off.
- The Cunningham is led outside the Boom gooseneck and Vang blocks through the pad eye welded on the gooseneck, through the sail grommet and tied off to the opposite pad eye.

### **Boom Vang:**

- When your Vang is all the way on it should pull the end of the boom down about 7,6 cm past 90 ° as referenced from the mast. You need a lot of Vang to be fast on those breezy reaches!
- The maximum “Vang off” position is when the end of the boom can be lifted approximately 46 cm off the transom. This can be adjusted to your height. A quick measure is to place your elbow on the transom and then you should be able to lift the boom to the end of your fingers.
- Always check over your Vang system for wear before sailing as it takes a lot of load. Broken Vangs are almost impossible to fix on the water.

Lever Bar Vang - Adjust pins in lever arm and plate to get the proper range of motion.

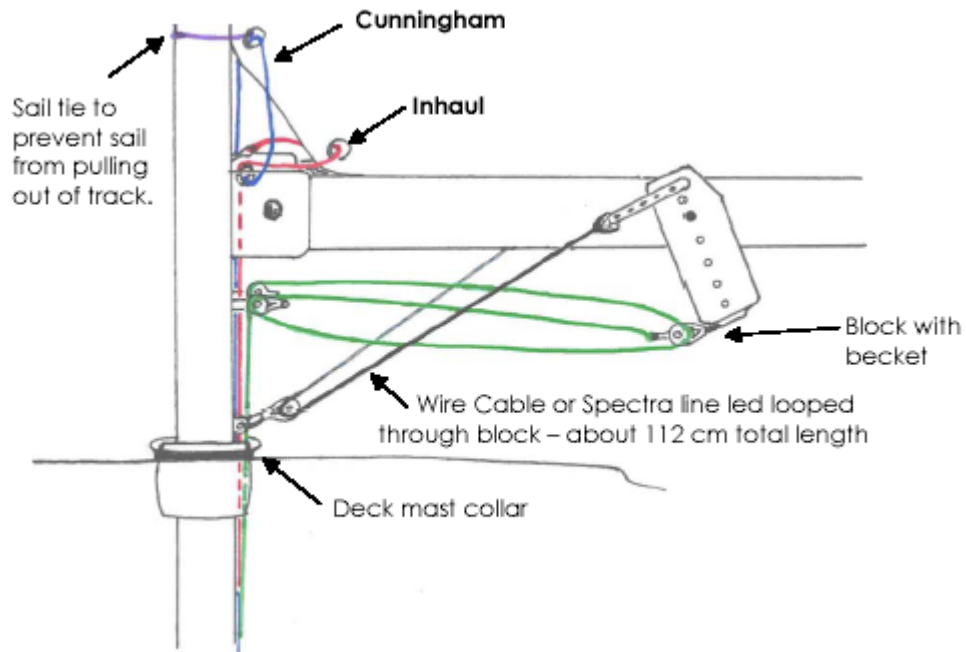

Cascading Vang - Adjust Wire Cable or Spectra line length to get the proper range of motion. Make sure that the eye stop cannot be pulled forward (perhaps with a nail in front of the screw). There is coming a lot of load it.

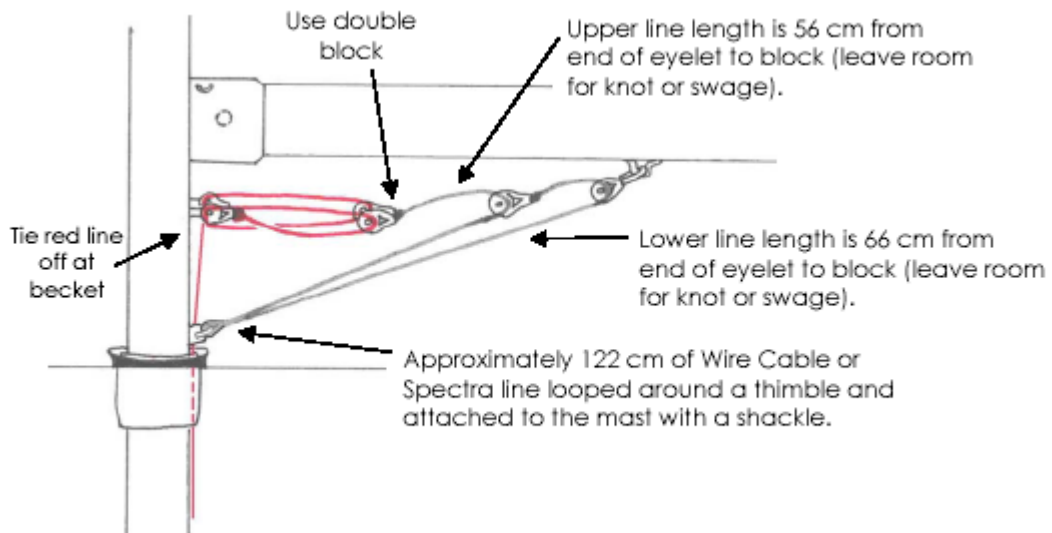

### Deck Control Lines:

- Use four different color lines if possible to make it easier to find the right control line at those crazy mark roundings.
- Follow the diagram below for rigging order. I highly recommend rigging the Outhaul control line through the top tank block (as shown). Therefore, when you rig your boat after traveling, you just reach for the top block and tie on your Outhaul line from your boom. This makes it hard to cross the other inside control lines.

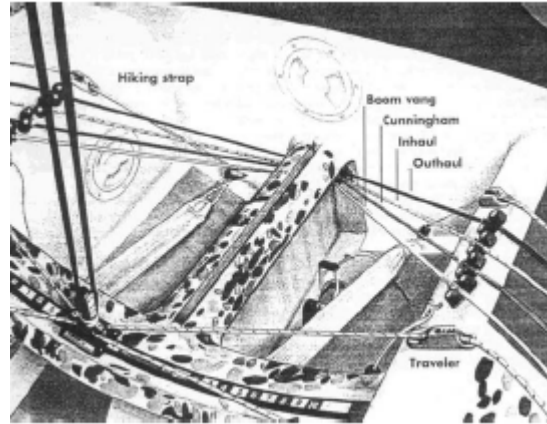

### Mainsheet:

- Move the Boom eye straps (make sure these are firmly connected to the boom so that they cannot be pulled forward) for your mainsheet system as close together as possible and center it above your traveler. Basically, if your system is rigged at an angle you are not only attempting to pull the boom down but over. This feels like twice as much work to pull in your sail – and in fact is.
- Tie your mainsheet off to the first eye strap rather than a becket on your upper mainsheet block. This way, if one of your eye strap fails or shifts you can still sheet in your boom.

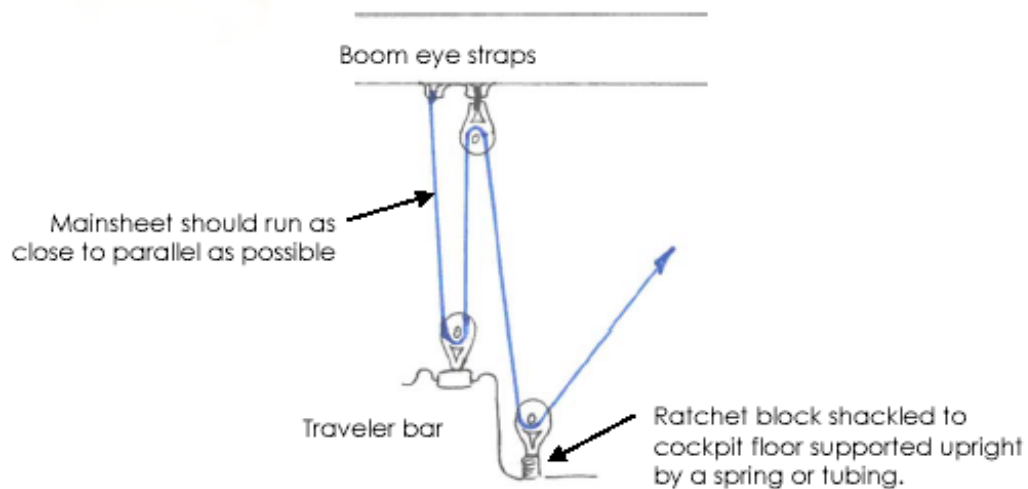

## Halyard Wire, Hoist and measuring Mast Rake:

- Make sure your halyard wire is the right length with the swages in the right locations to hoist your sail all the way up to the band. You can fudge a bit by getting a different size halyard shackle. If your sail is not fully hoisted you will be slow! Watch out there is a difference in distance between the upper part of the sail and the upper part of the hole in the sail between sails of different sail makers.

- Make an extra halyard wire and bring it to all your regattas. Tie it on to your boat.

- **BUY YOUR OWN TAPE MEASURE.** Try to get a metric one not shorter than 8 m. If you can't find a metric tape, just mark in the centimeter increments between 5.20-5.70 m feet with a permanent marking pen.

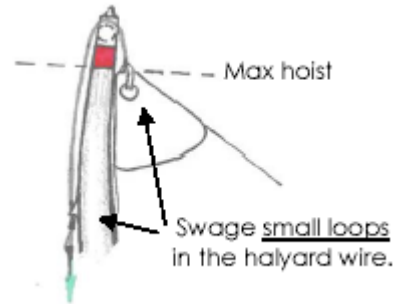

- Attach a ring-ding to the end of the tape measure so you have something to attach your halyard shackle to when measuring your rake.
- To measure your rake: Hoist your tape up the mast and lock in the halyard. Pull the tape down to the stern of the boat, even with the deck, above the gudgeons as shown in the diagram. Push down on the stern allowing the mast butt to shift forward (causing the mast tip to shift back) putting the mast in "sailing" position. Pull the tape snug but don't bend the mast. With Green Sails, 540 cm is looking like a good rake to start at and with the WB Sails, 545 cm is working. Watch out with radial sails the mast has to be put more forward. WB has even radial sails (code LL) for the more weighty sailors that have a longer than standard leech. The mast middle position is than about 554 cm.

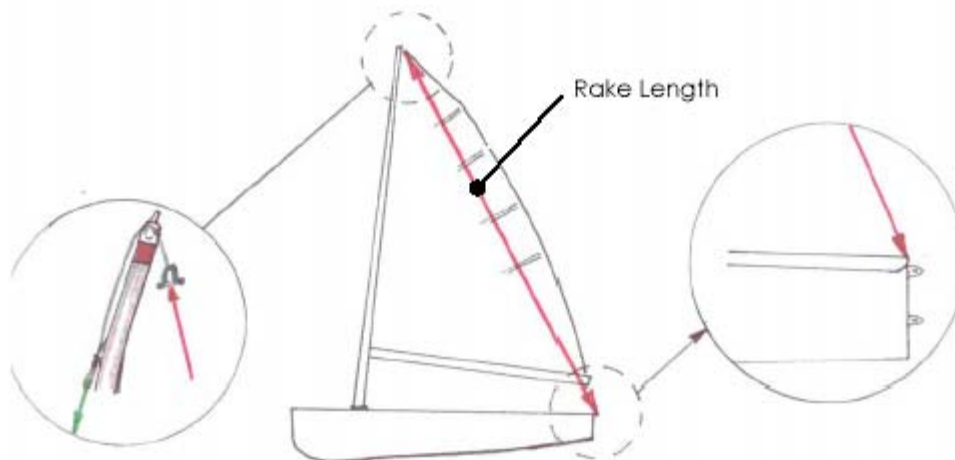

## Rudder Angle:

- There should be none. The back of your rudder should sit parallel to the stern of your boat otherwise you will have terrible weather helm. Steering is even more easy with the rudder angled under the boat, but that is illegal.
- If you can't keep the rudder from kicking up then you should bolt completely through your rudder and rudder head using a small diameter bolt or pin. Make sure that you reinforce the hole in the blade with a plastic or metal tube so that it can not become any bigger
- Measure your rudder angle while it is attached to your boat.

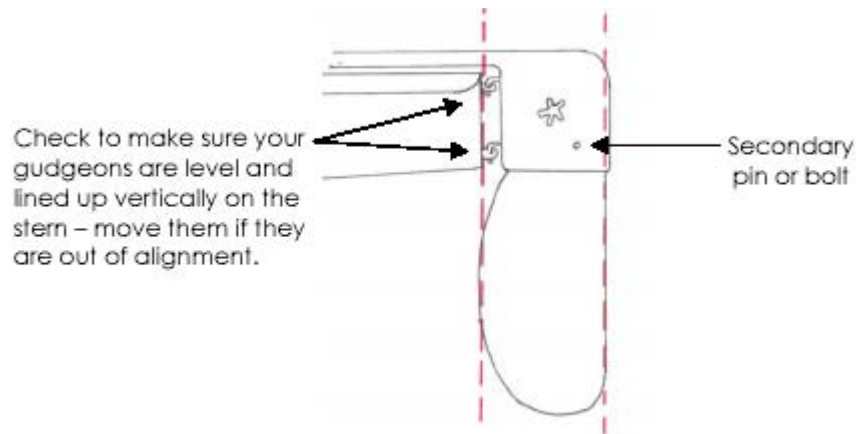

## Centerboard:

- The Centerboard should fit snugly in the CB trunk because its position (height, angle) is key. Add electrical tap or packing tape to the inside of your CB trunk until the Centerboard fits snugly enough to stay put during sailing. If you have not got this tape use sail numbers

## Appendix: "Purchase"

Susie only has to tug with **25** pounds of force using her purchase system to drag her **100** pounds mule "Buttercup" into the barn. Note that her effort is reduced by a factor of 4 – this purchase is "4:1".

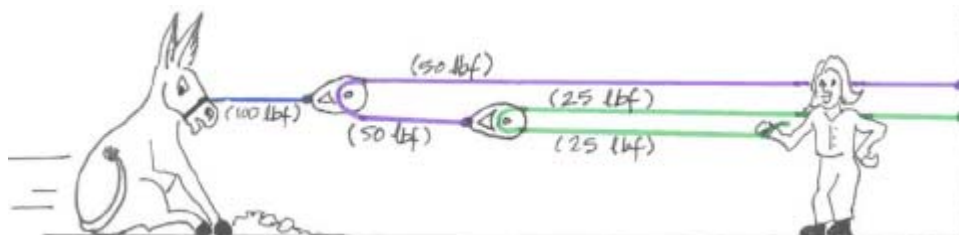



### **A Sailors suggestion**

#### **Boom pulley for easy downwind sailing in light breezes.**

If you do not want to have problems with keeping your boom out on downwind legs in light airs do this: Attach a small block to your bow. Then apply a shock cord from the first eye stap of your mainsheet through the block at the bow and back past the other side of the mast to the eye stap.

